



NOVAS TECNOLOGIA ADOTAR OU NÃO?

3 MOTIVOS PARA ADOPTAR UMA NOVA TECNOLOGIA



REDUZIR CUSTO



AUMENTAR VGV



RESOLVE UM PROBLEMA

MOTIVOS PARA ADOTAR UMA NOVA TECNOLOGIA



**REDUZIR
CUSTO**



**AUMENTAR
VGV**



**RESOLVE UM
PROBLEMA**



2014 – COSMOPOLITAN JOINVILLE



Área impermeabilizada = 2.900 m²

2 subsolos

Outros projetos finalizados

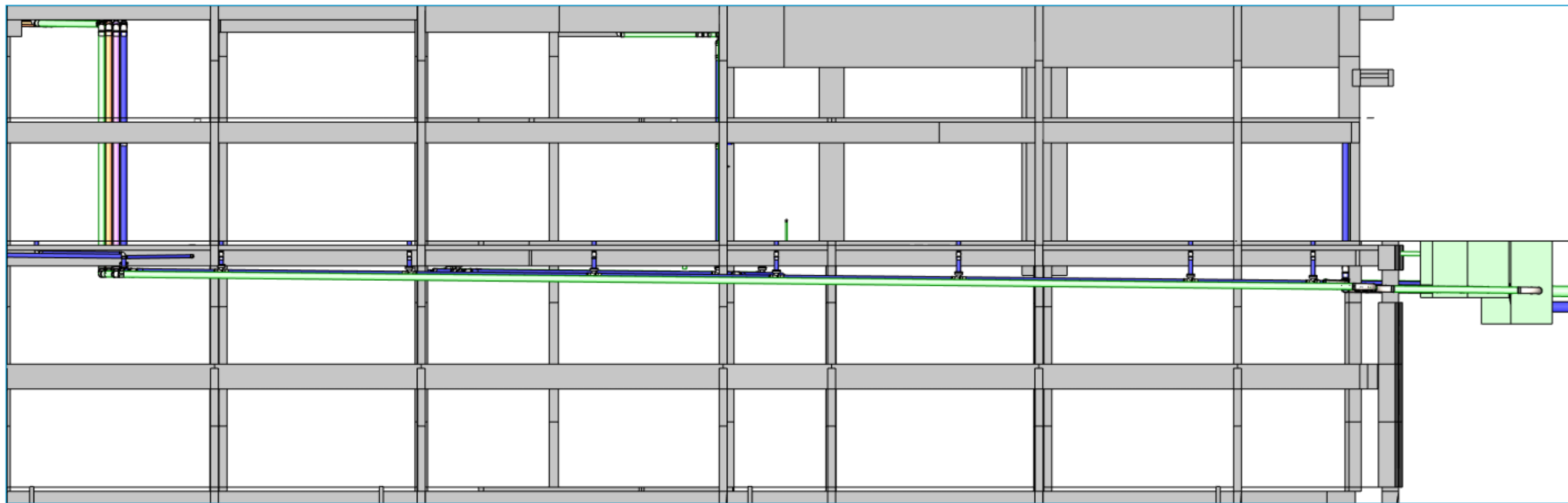





2011

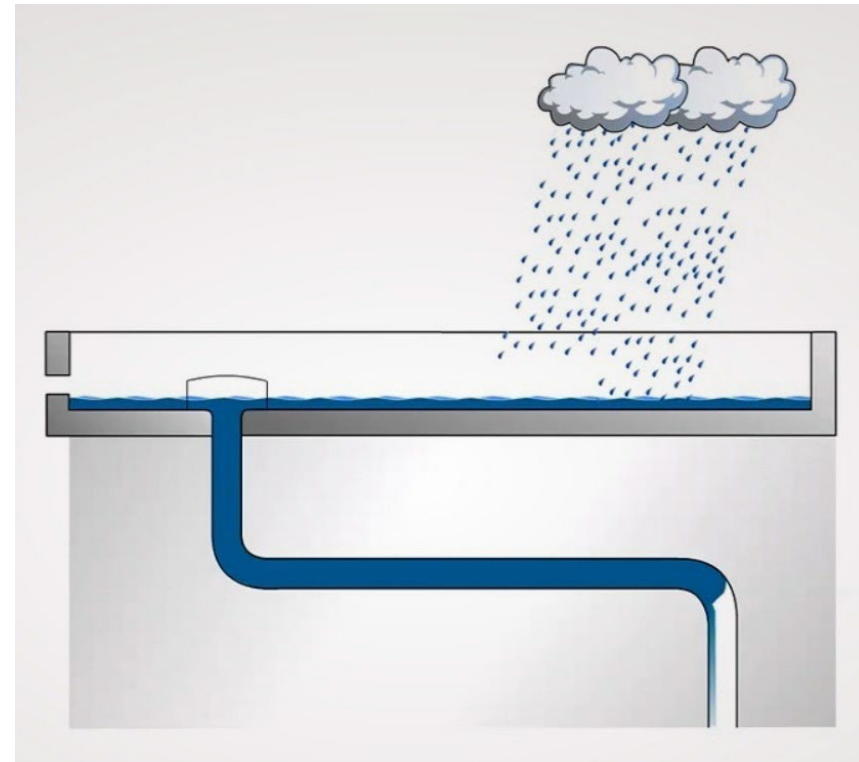



X



R\$ 20 mil mais barato

FOI ADOTADO?

MOTIVOS PARA ADOPTAR UMA NOVA TECNOLOGIA



**REDUZIR
CUSTO**



**AUMENTAR
VGV**



**RESOLVE UM
PROBLEMA**



NÃO FOI ADOTADO

JUNHO DE 2013

NORMA DE DESEMPENHO



MOTIVOS PARA ADOPTAR UMA NOVA TECNOLOGIA



**REDUZIR
CUSTO**



**AUMENTAR
VGV**



**RESOLVE UM
PROBLEMA**

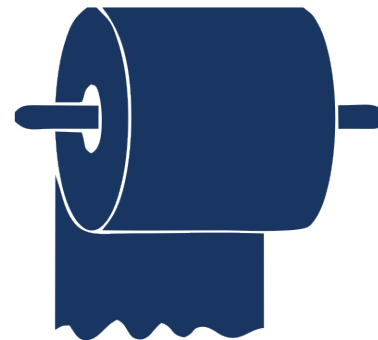

**QUEM FAZ A
MANUTENÇÃO?**



AQUA - IMBITUBA SC



SISTEMA DE AQUECIMENTO CENTRAL

INVESTIMENTO ADICIONAL

R\$ 300mil

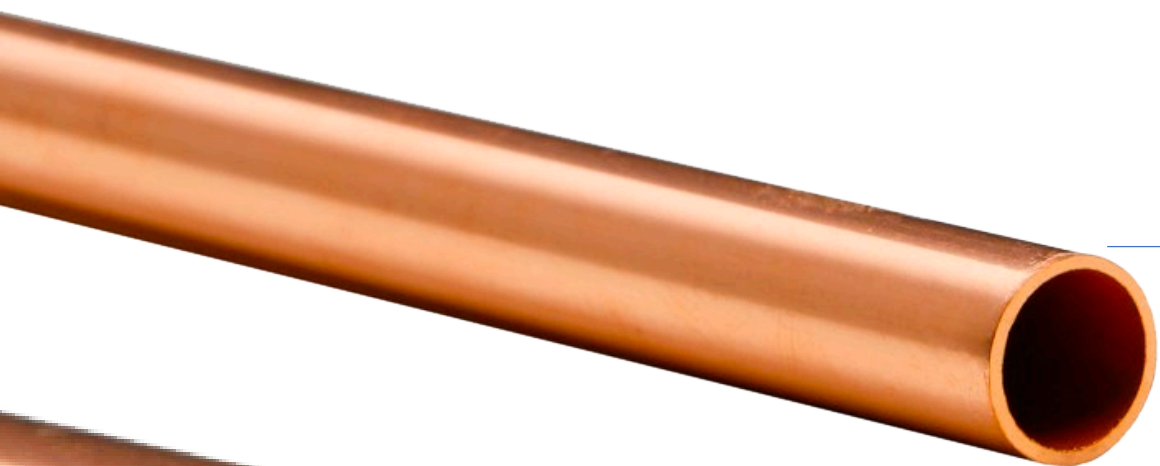

1,5cm



3,0cm

DIMINUIÇÃO DO CONTRAPISO



**REDUZIR
CUSTO**



**AUMENTAR
VGV**



**RESOLVE UM
PROBLEMA**

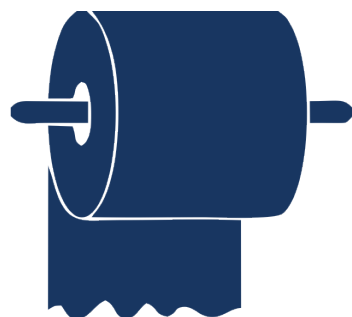

**QUEM FAZ A
MANUTENÇÃO?**



CRIANDO ESPAÇO NO CÉU

SISTEMA DE PRESSURIZAÇÃO

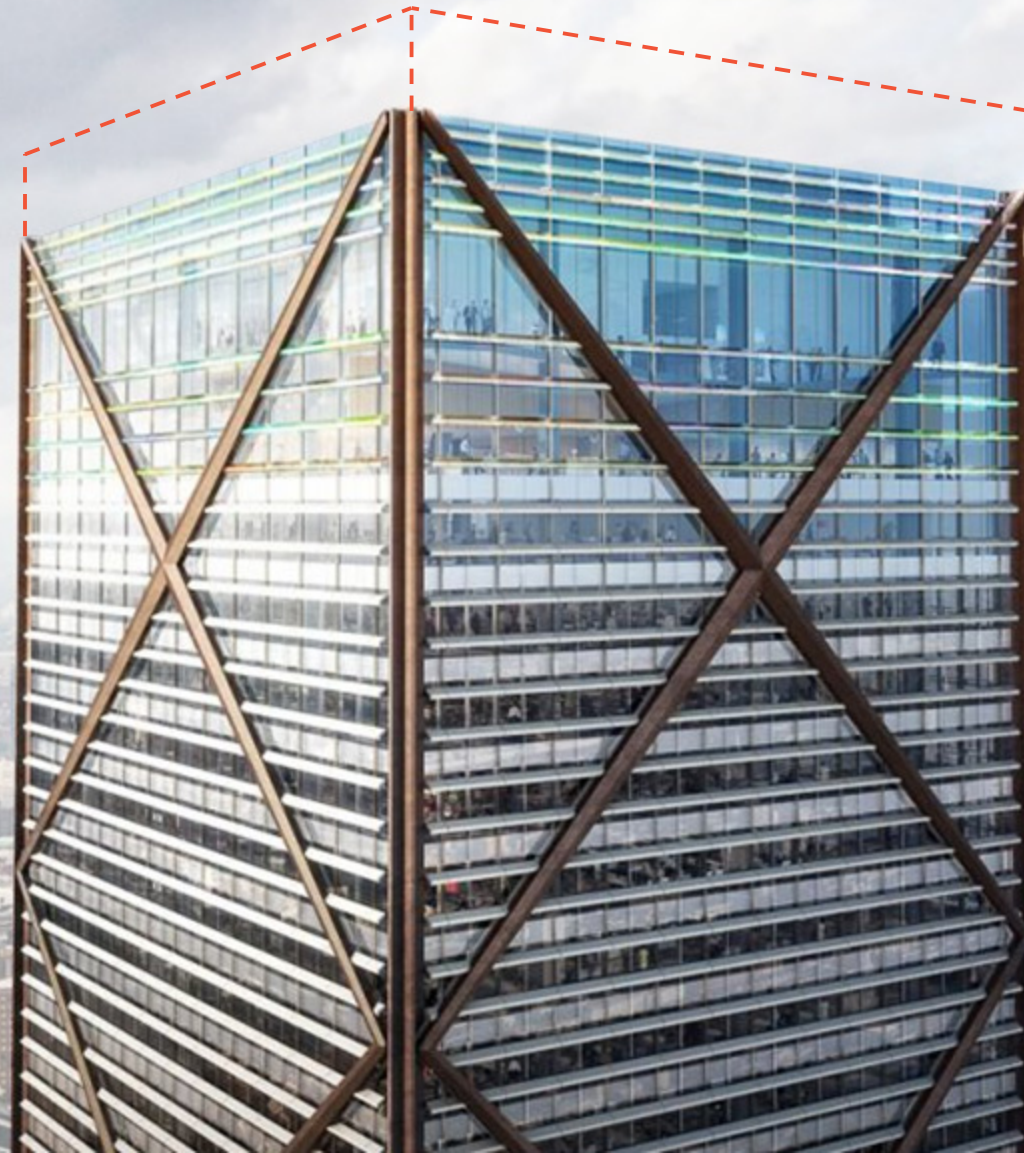

ZENITH TOWER – CHAPECÓ SC

SITUAÇÃO ATUAL

LIMITAÇÃO DE ALTURA DE ALTURA
DEVIDO AO AEROPORTO
37 PAVIMENTOS

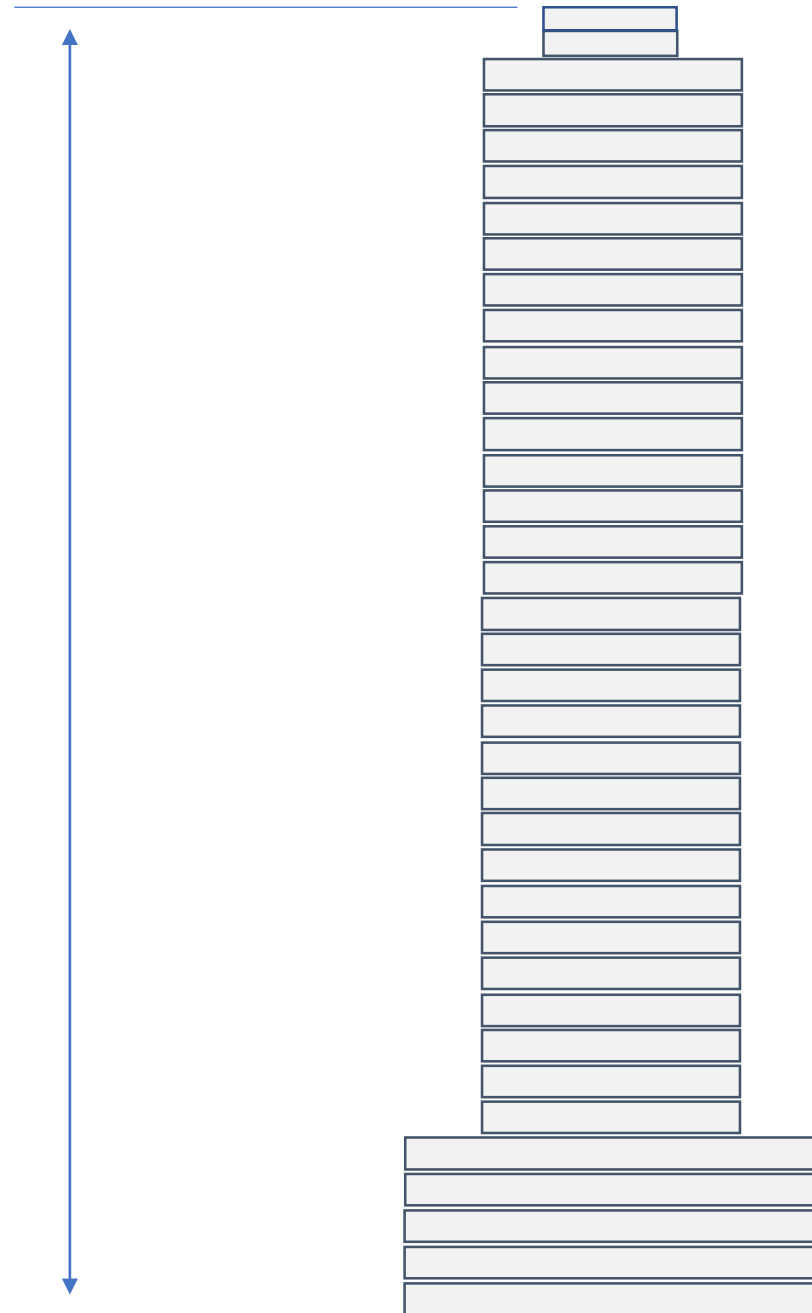

SITUAÇÃO ATUAL

SISTEMA DE RESERVATÓRIOS
TRADICIONAL
37 PAVIMENTOS

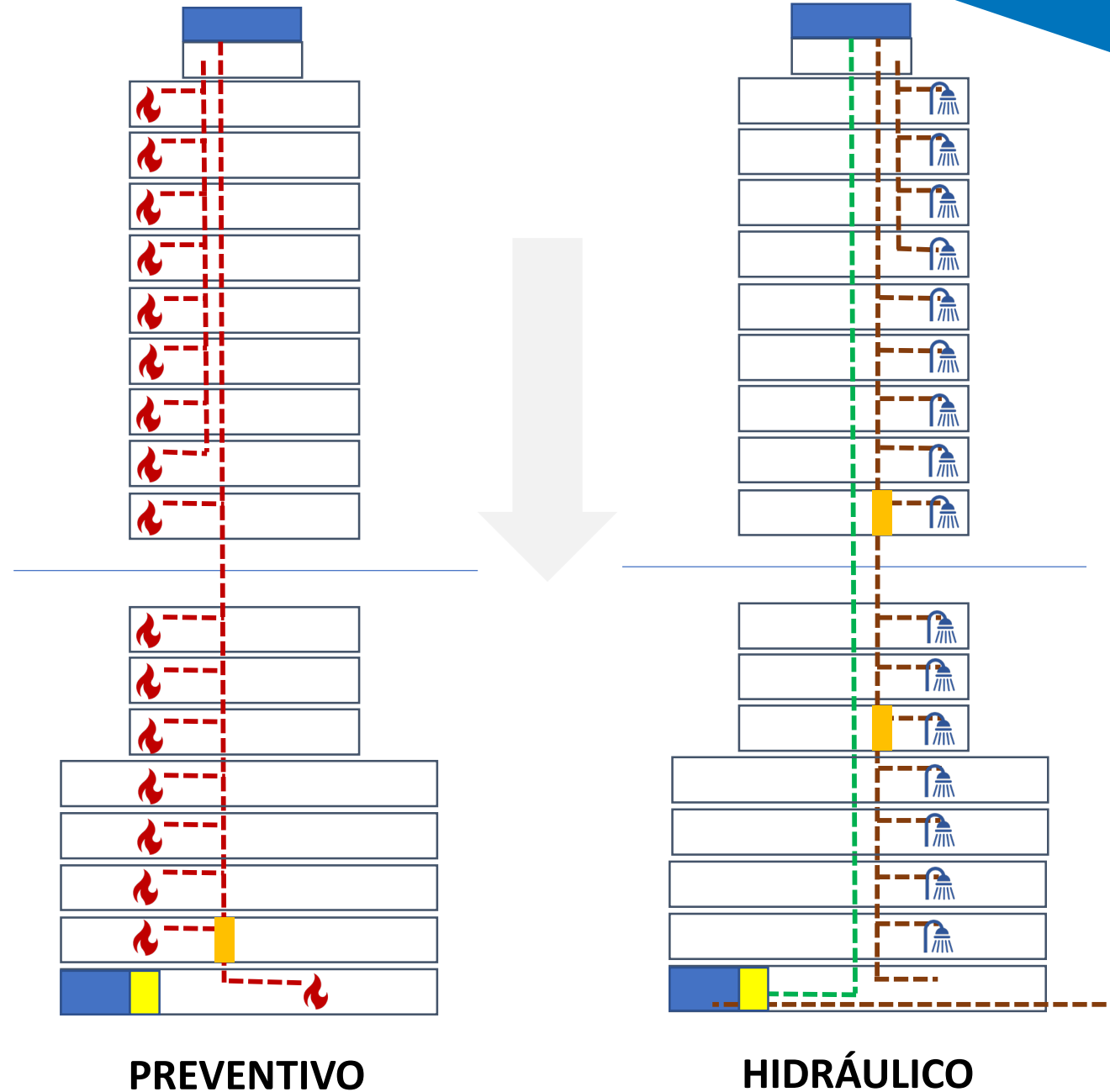

PREVENTIVO

HIDRÁULICO

SISTEMA PRESSURIZADO

RESERVATÓRIOS SOMENTE
NO TÉRREO
38 PAVIMENTOS

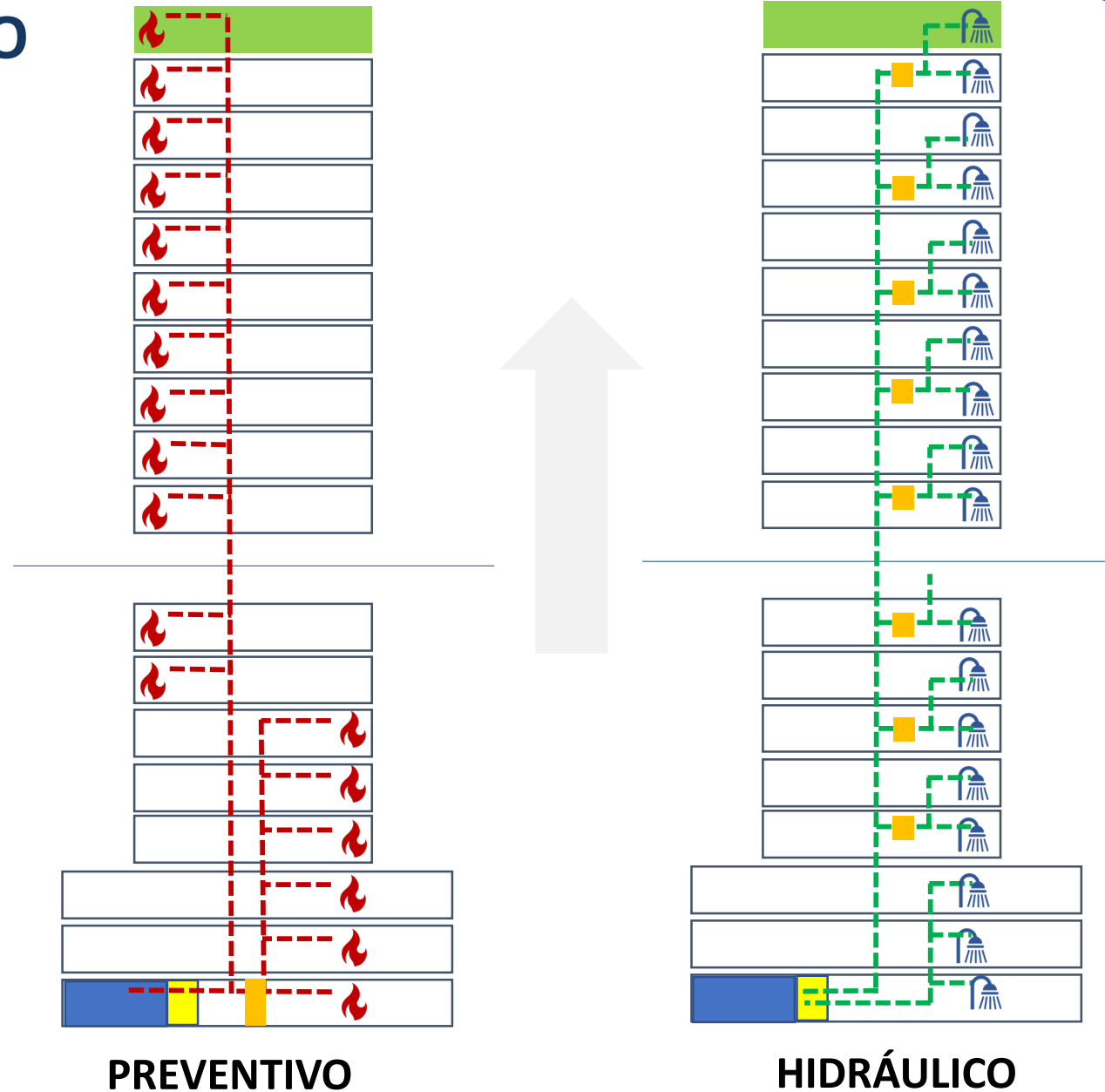

SISTEMA PRESSURIZADO



BOMBAS PRESSURIZADORAS EM SÉRIE COM COMANDO ESPECIAL

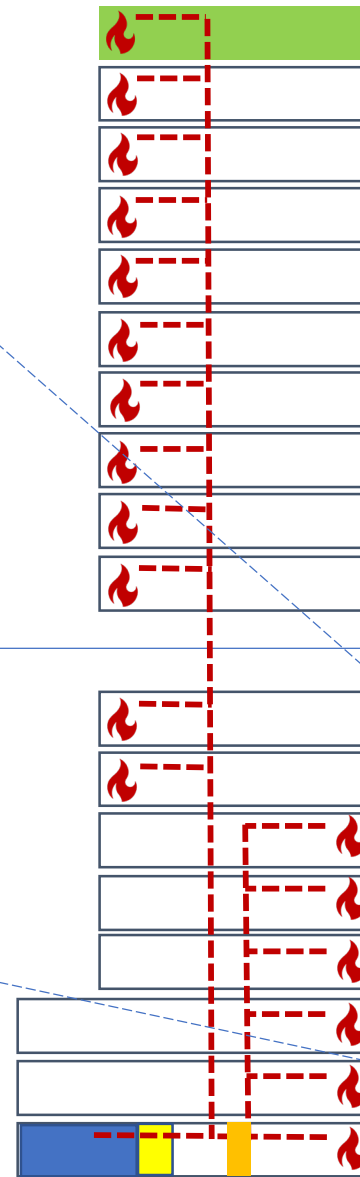

PREVENTIVO

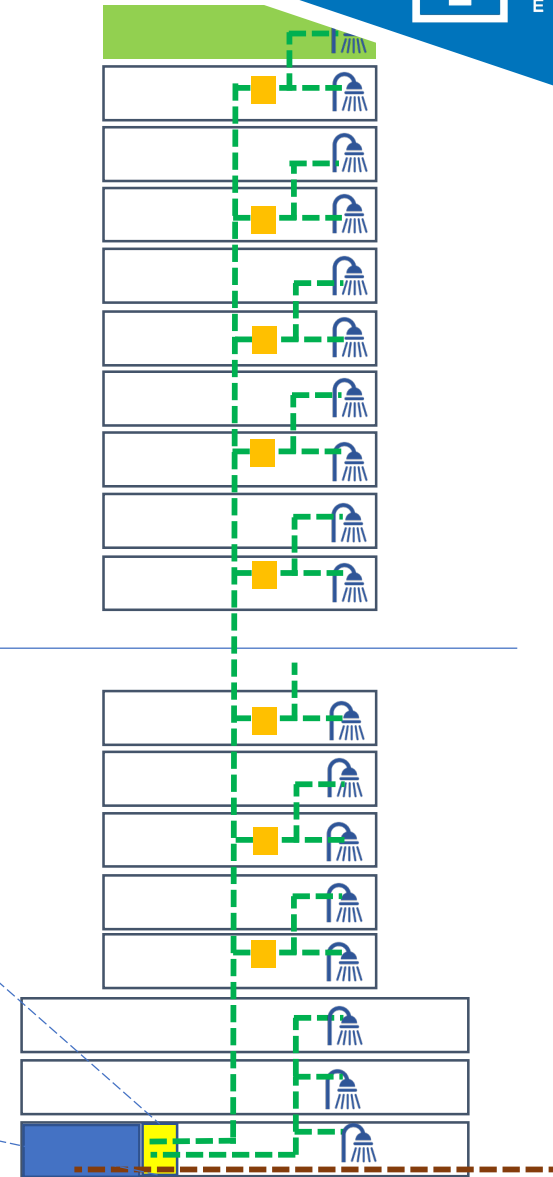

HIDRÁULICO

SISTEMA PRESSURIZADO



TANQUE DE PRESSÃO

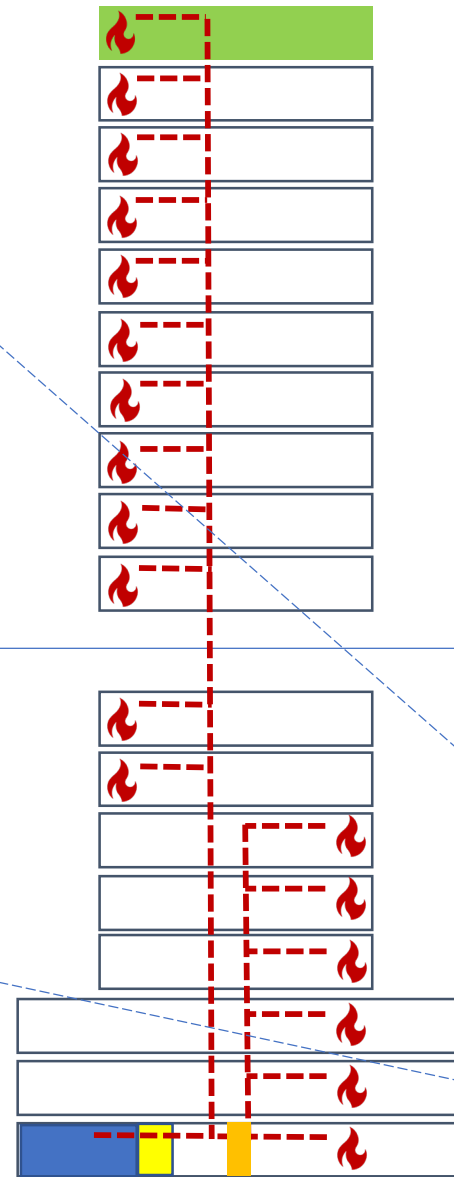

PREVENTIVO

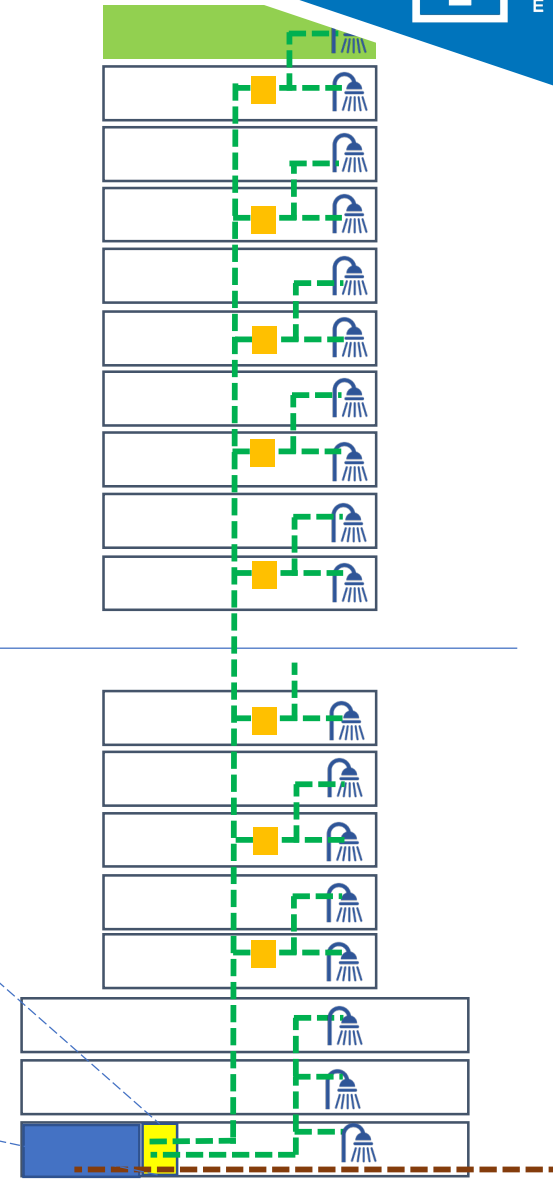

HIDRÁULICO

SISTEMA PRESSURIZADO



BOMBAS PRESSURIZADORAS PARA TORNEIRAS DE JARDIM NAS GARAGENS E LAZER

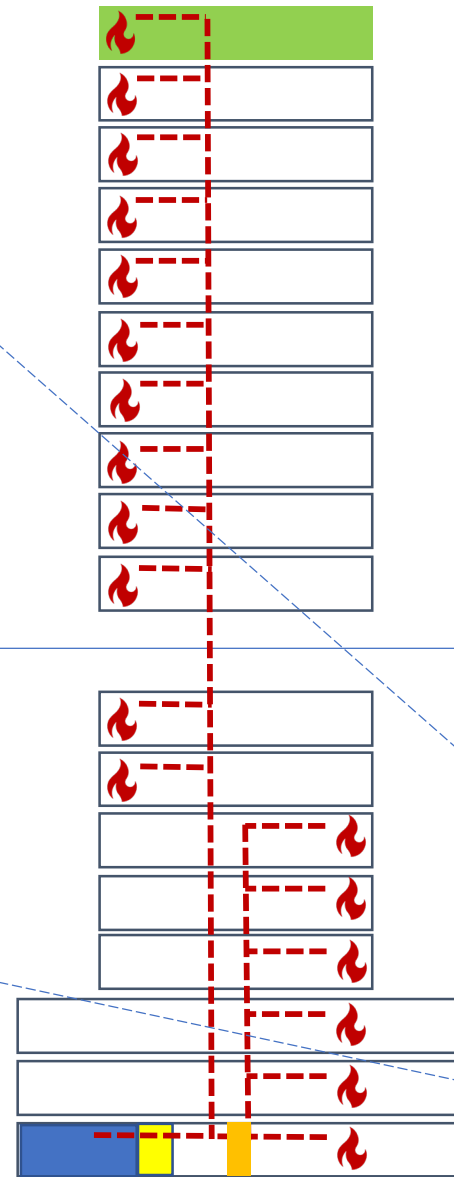

PREVENTIVO

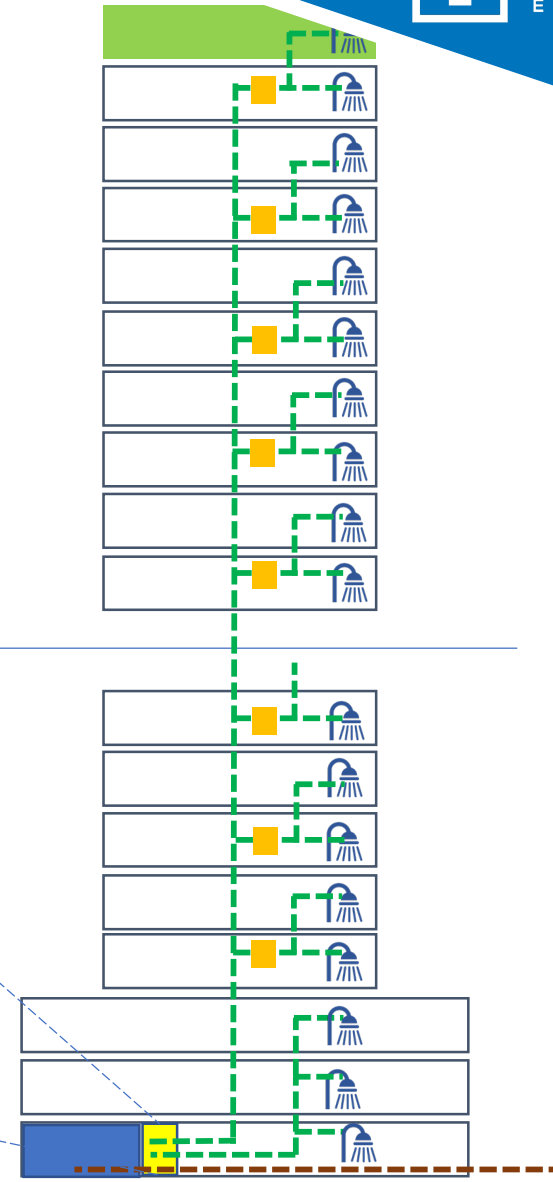
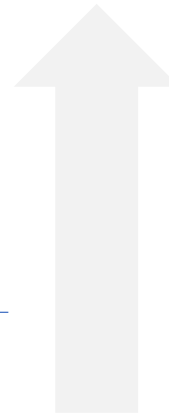

HIDRÁULICO

SISTEMA PRESSURIZADO

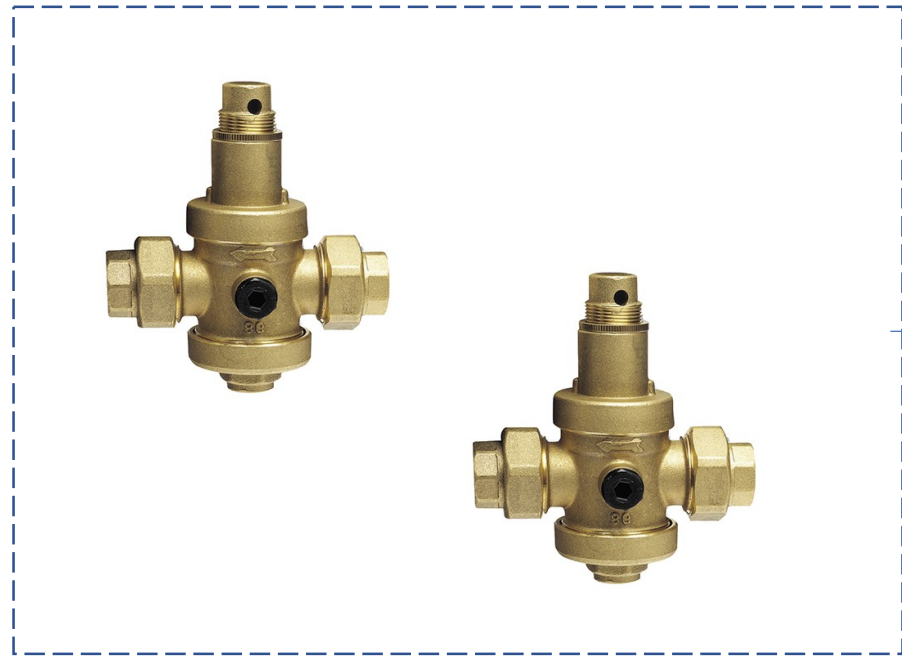

VALVULAS REDUTORAS DE PRESSÃO A CADA DOIS ANDARES

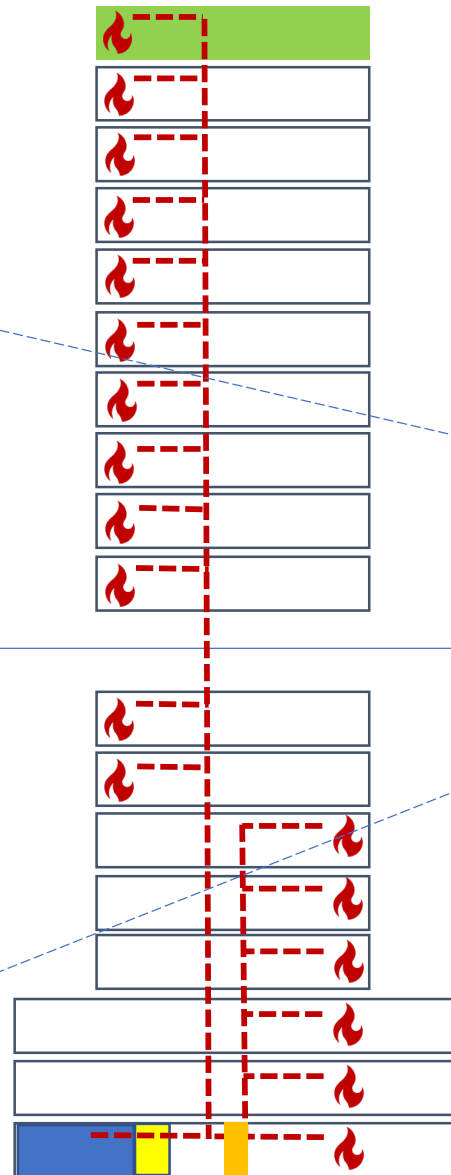

PREVENTIVO

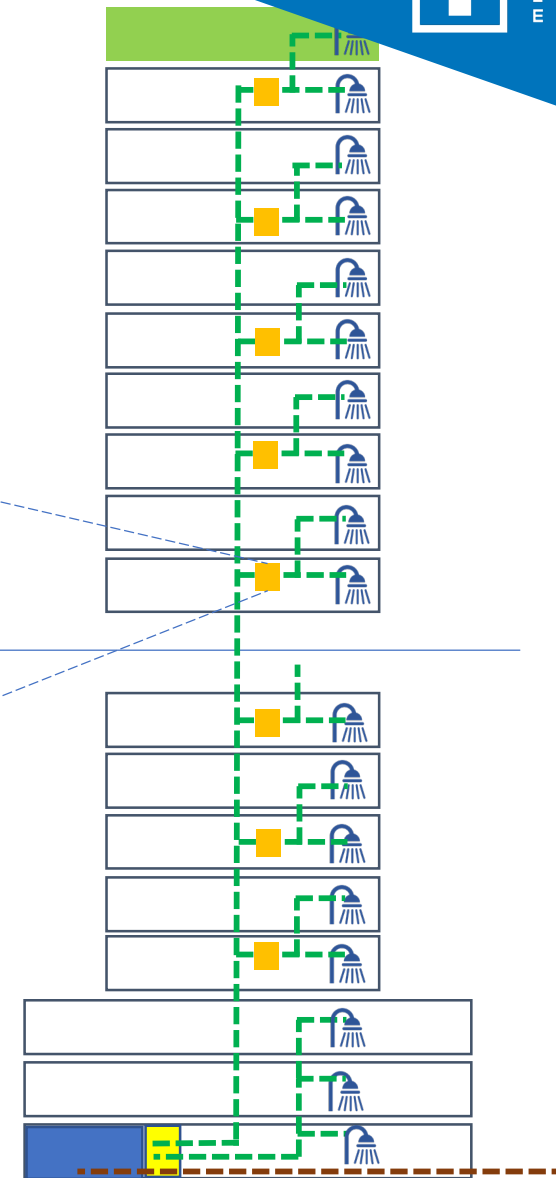

HIDRÁULICO

SISTEMA PRESSURIZADO



BOMBAS MAIORES PARA REDE DE MANGOTINHOS

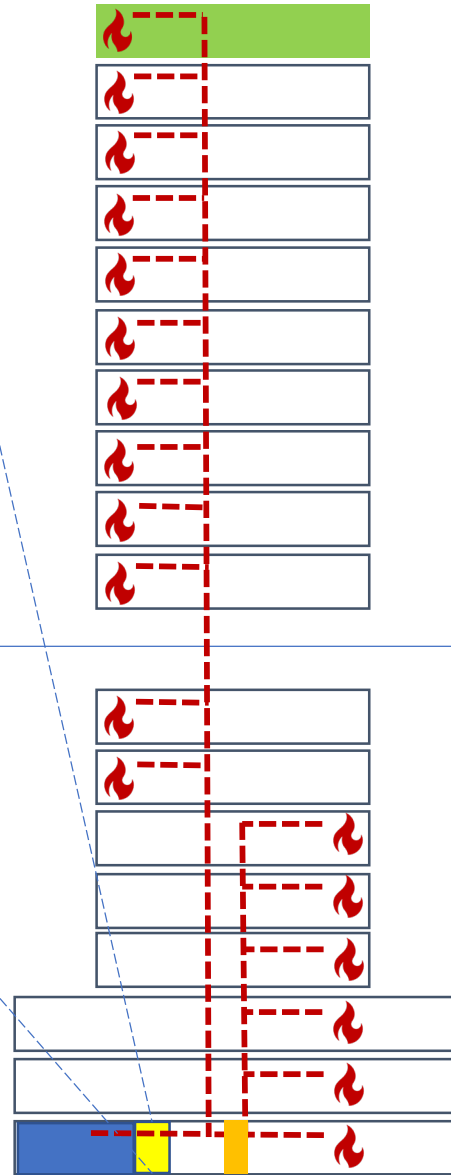

PREVENTIVO

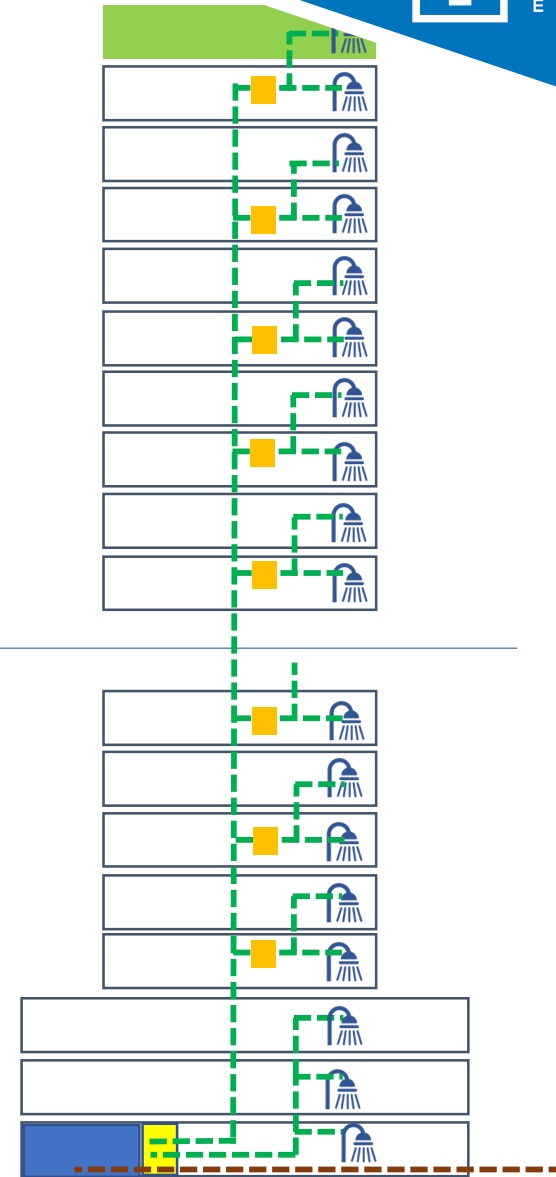

HIDRÁULICO

VIABILIDADE FINANCEIRA - SISTEMA PRESSURIZADO

ITEM	TOTAL
VGVLÍQUIDO ADICIONAL	1.285.000
INVESTIMENTO CONTRUÇÃO	-685.000
INVESTIMENTO EQUIPAMENTOS	-100.000
RETORNO	500.000
ROI – RETORNO SOBRE O INVESTIMENTO	63,7%

FOI ADOTADO?



**REDUZIR
CUSTO**



**AUMENTAR
VGV**



**RESOLVE UM
PROBLEMA**

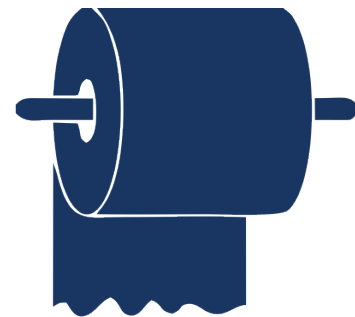

**QUEM FAZ A
MANUTENÇÃO?**



FOI ADOTADO



VILA OLÍMPICA - RJ

Independência
Rua da Independência
Cristo Redentor
Cep 95002-380

Maio
Rua Treze de Maio
Cristo Redentor
Cep 95061-450

RESIDENCIAL NUOVA VITA – CAXIAS DO SUL - RS





RESIDENCIAL SAGUAÇU – JOINVILLE - SC

Um profissional bom é o que te da alternativa





PROJETOS DE ENGENHARIA PARA CONSTRUTORAS

Cristiano Schneider

cristiano@thorusengenharia.com.br

|47| 9 8405 3698

thorusengenharia.com.br