



TECNISA S.A.

October, 2011

34 ANOS

LANÇAMENTOS (R\$ Mi)

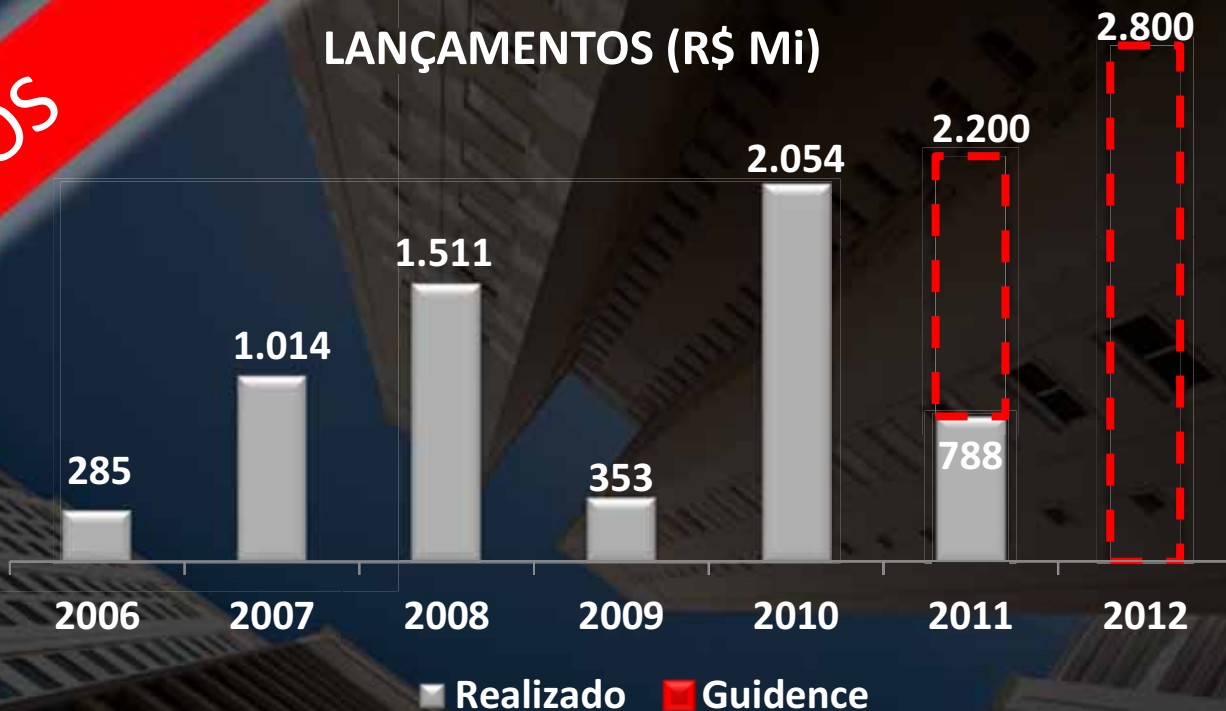

■ Realizado ■ Guidence

**Staff
2500**

2009



**Staff
6000**

2010



CENÁRIO

DEMANDA

DISPONIBILIDADE

CUSTO

QUALIDADE

EXPECTATIVA CLIENTE

PRAZOS DESAFIADORES

NORMA DE DESEMPENHO

EFEITO NO MERCADO



PLANEJANDO EMPREENDIMENTOS

ast ddt dqp obr orç engenharia per planejamento prjproduto prjexe sup

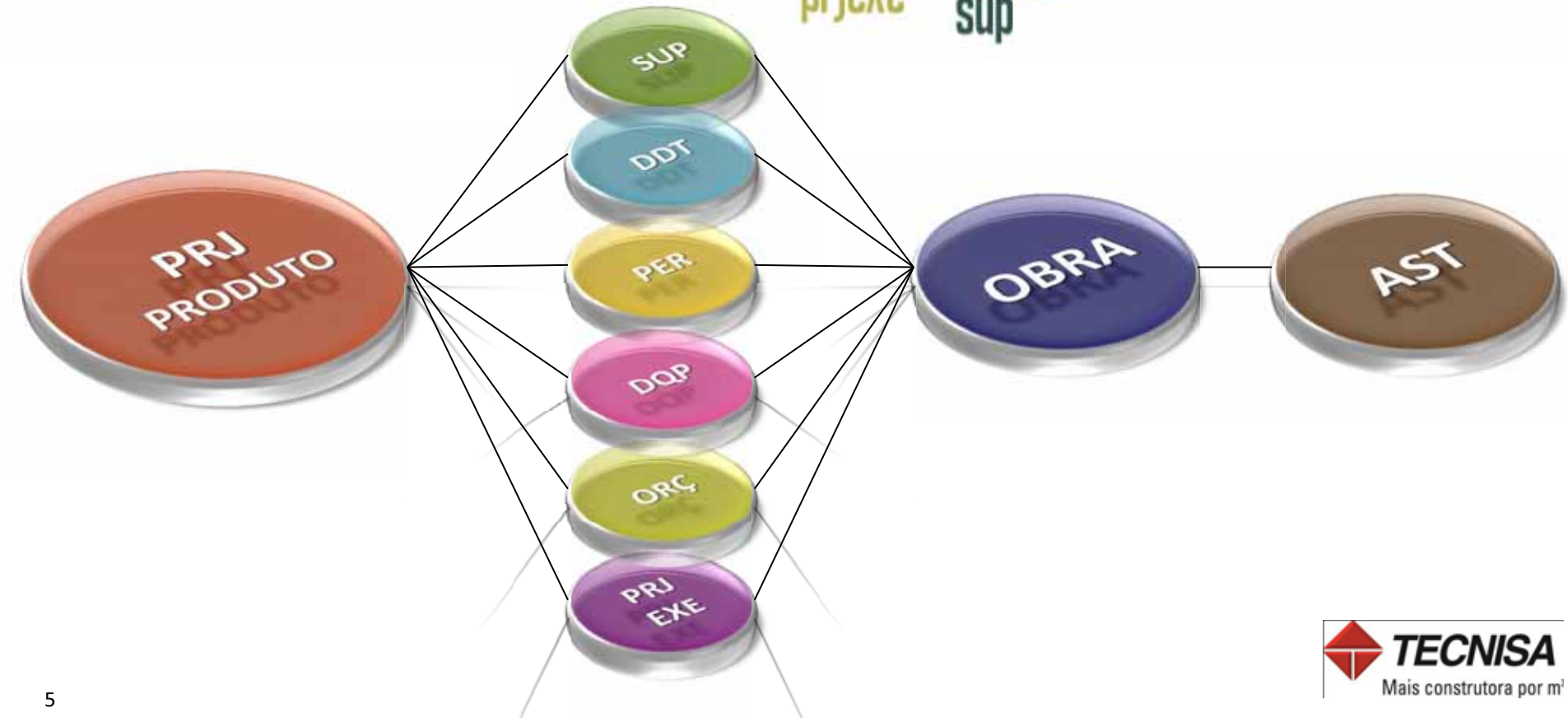

COMO **COMPARTILHAR** CONHECIMENTO NO **CANTEIRO?**

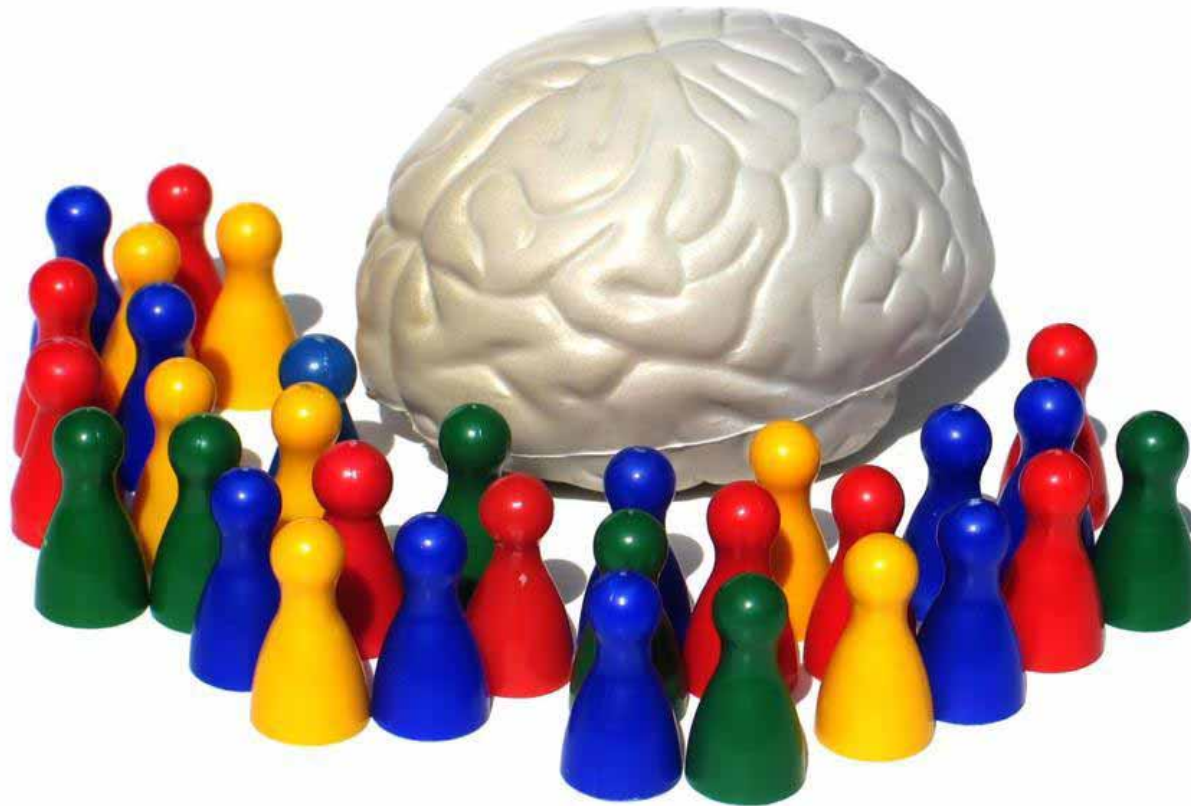

Sr. **Pereira**: o especialista em fazer **estrutura** de concreto

25 anos trabalhando conosco!

1 semana por **canteiro**

2010: mais de **1350** horas de treinamento



PROGRAMAS DE TREINAMENTOS



- ✓ Realização de Treinamentos em Campo;
- ✓ Orientação em tempo real;
- ✓ Capacitação e motivação de equipes.



+ DE 2.100 HORAS E
1400 COLABORADORES IMPACTADOS

DEPARTAMENTO DE PROJETOS PARA PRODUÇÃO

CONSTRUINDO NOVOS CAMINHOS



TECNISA
Mais construtora por m²

TECNISA

PROJETOS PARA PRODUÇÃO

Passo a passo



Auxílio no Planejamento

Paginação de Cerâmicas

Redução de perdas

Interferências com Stands



Economia em Projetos: **R\$ 1 milhão**

Economia potencial em cerâmicas: **R\$ 5 mil / torre**
Estimativa para Viverde



PROJETOS PARA PRODUÇÃO

Escritório e canteiro

falando a mesma **língua...**

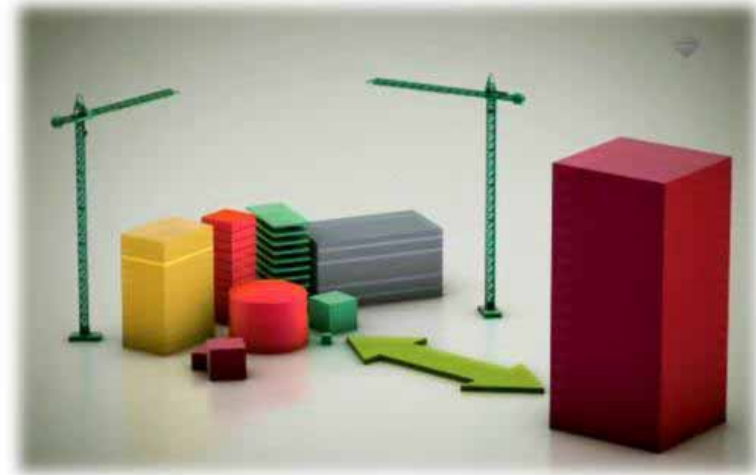

PLANEJAMENTO DE CANTEIRO

8 GRUAS ASCENSIONAIS

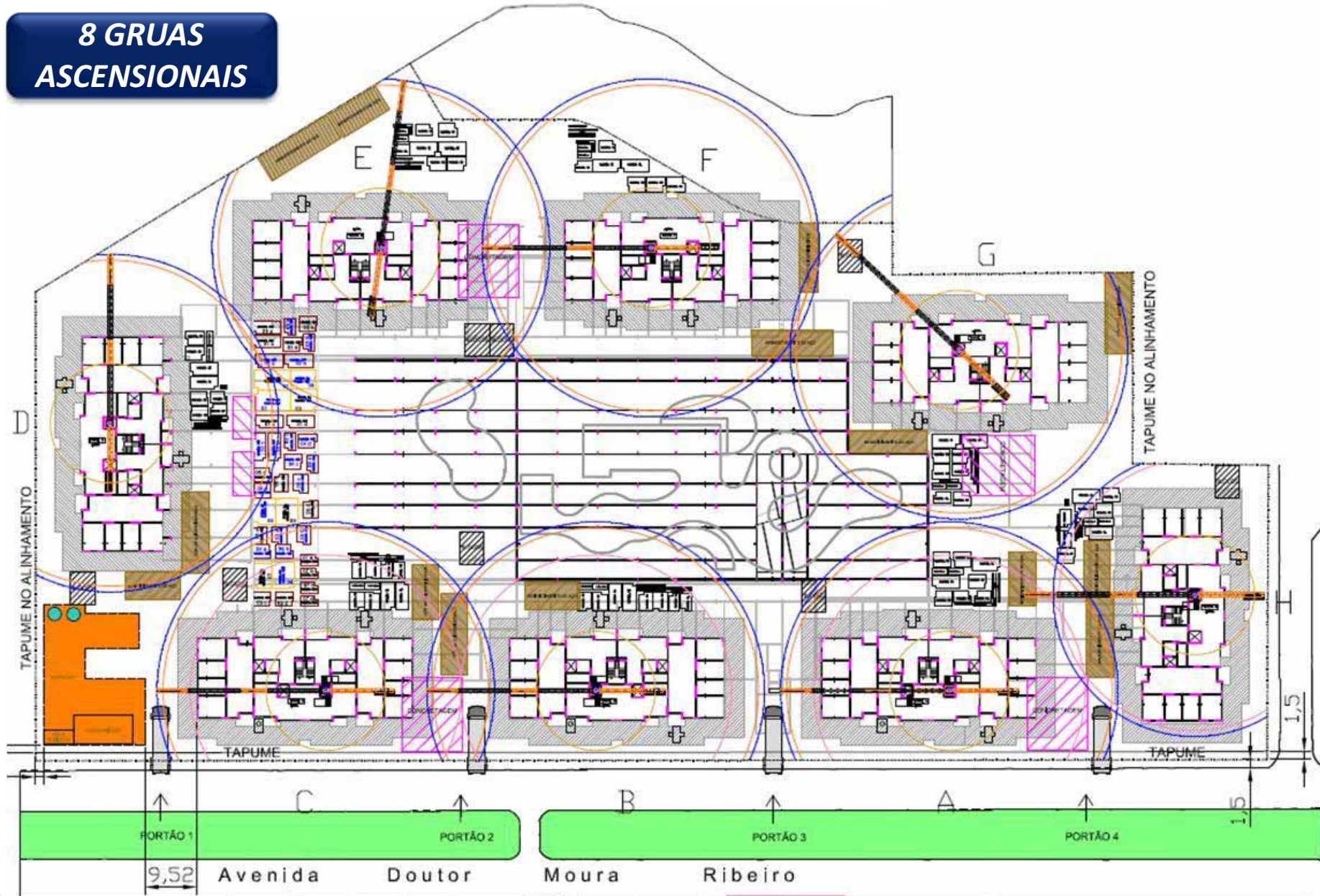

INDUSTRIALIZAÇÃO NO CANTEIRO



INDUSTRIALIZAÇÃO NO CANTEIRO



Redução de 25 - 30% da
equipe de carpintaria



Precisão geométrica
das peças



Acabamento



Segurança

CENTRAL DE FÔRMAS



Garantia de
Qualidade

Garantia de
Fornecimento

Industrialização do
Processo de
Fabricação de
Fôrmas

Otimização de
Custos e Recursos



MDO própria

10% mais econômico...

Em 2010 – 51.000
m² fabricados

INDUSTRIALIZAÇÃO DE INSTALAÇÕES

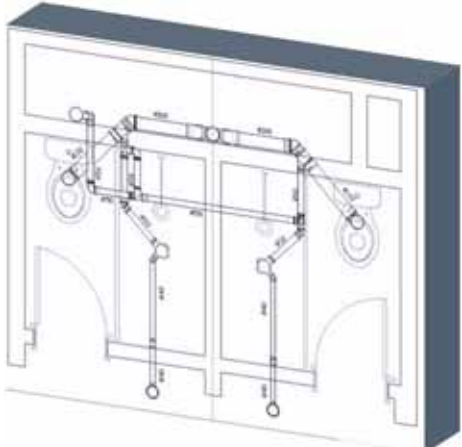

Antes

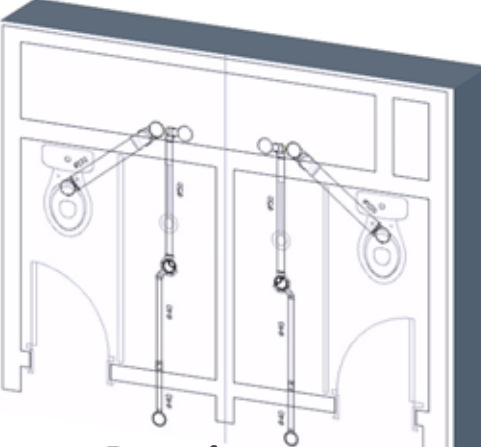

Depois

Mais de 20% de economia em materiais e MDO de esgoto sanitário!

Projetos para Produção: Kits Hidráulicos

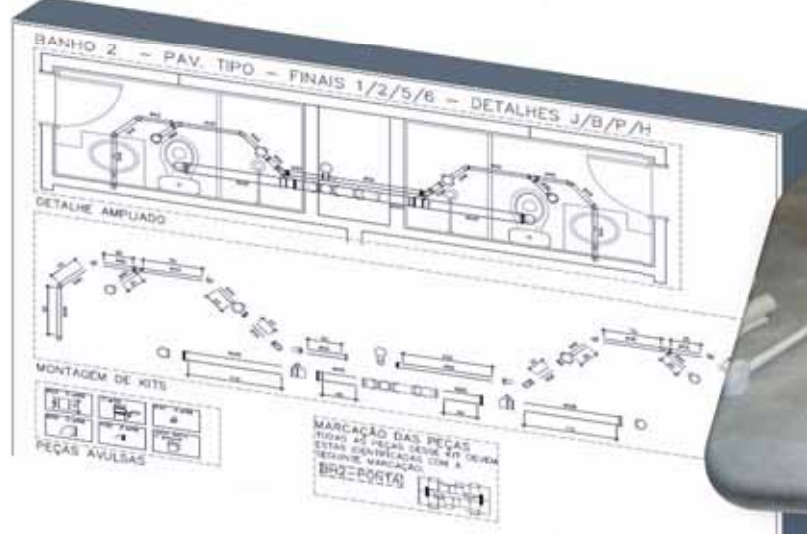

PAREDES DE CONCRETO

Análise de cenários



PAREDES DE CONCRETO

Análise de cenários

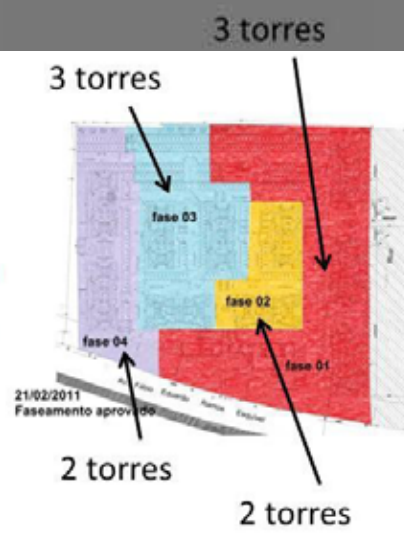
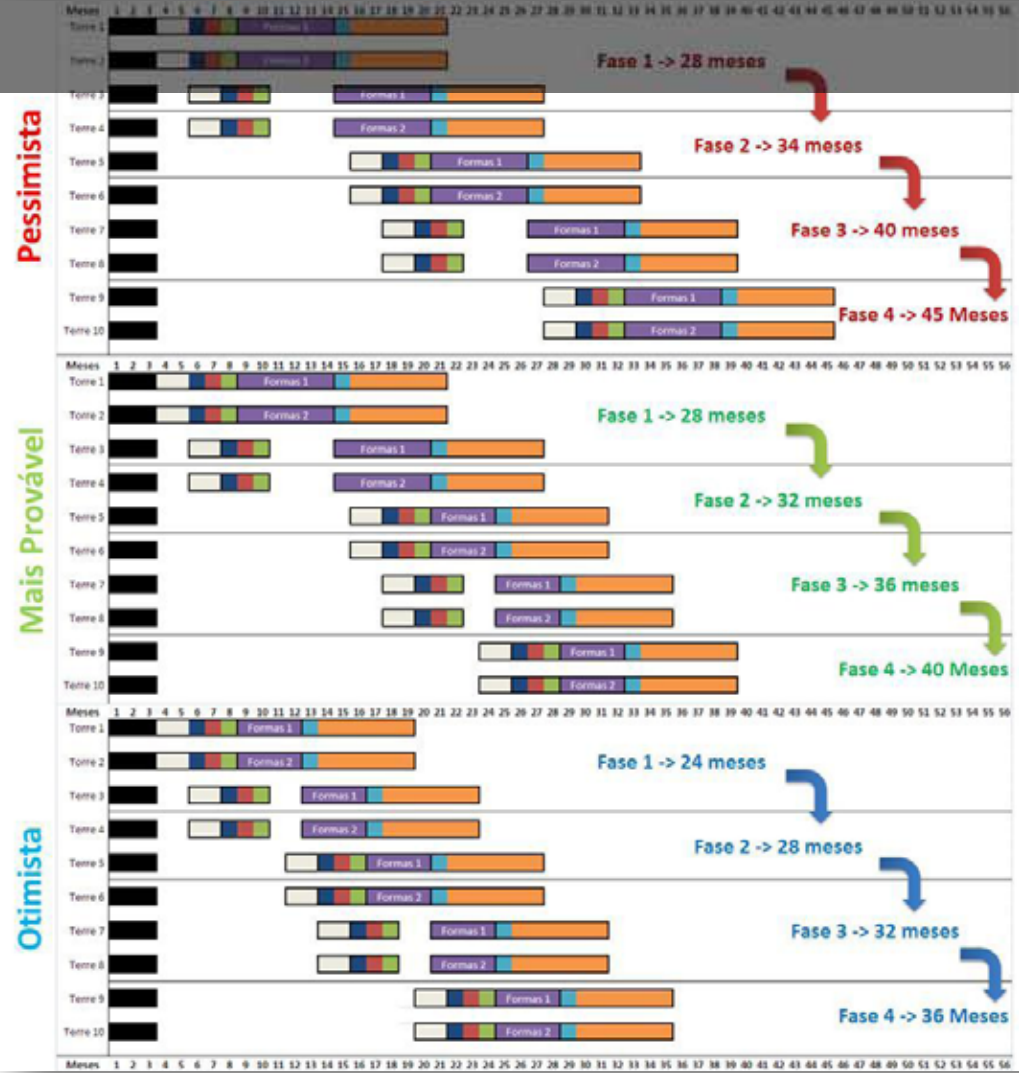

Legenda	
[Black]	Mobilização
[Grey]	Fundação
[Blue]	Escavação
[Red]	Blocos
[Green]	vigas baldrame e piso
[Purple]	Estrutura
[Light Blue]	Cobertura
[Orange]	Término

Redução da dependência da MDO

Aumento de margem

Possibilidade de redução de ciclo

NÓS NÃO
QUEREMOS
SER
GRANDES...



...MAS
CERTAMENTE
QUEREMOS SER
OS **MELHORES**



POR QUE SOMOS
DIFERENTES?



POR QUE A
GENTE SE
PREOCUPA



TECNISA

Mais construtora por m²



OBRIGADO!

Fabio Villas Bôas

villasboas@tecnisa.com.br